

# Munkahengerek

## Profil hengerek | ISO 15552

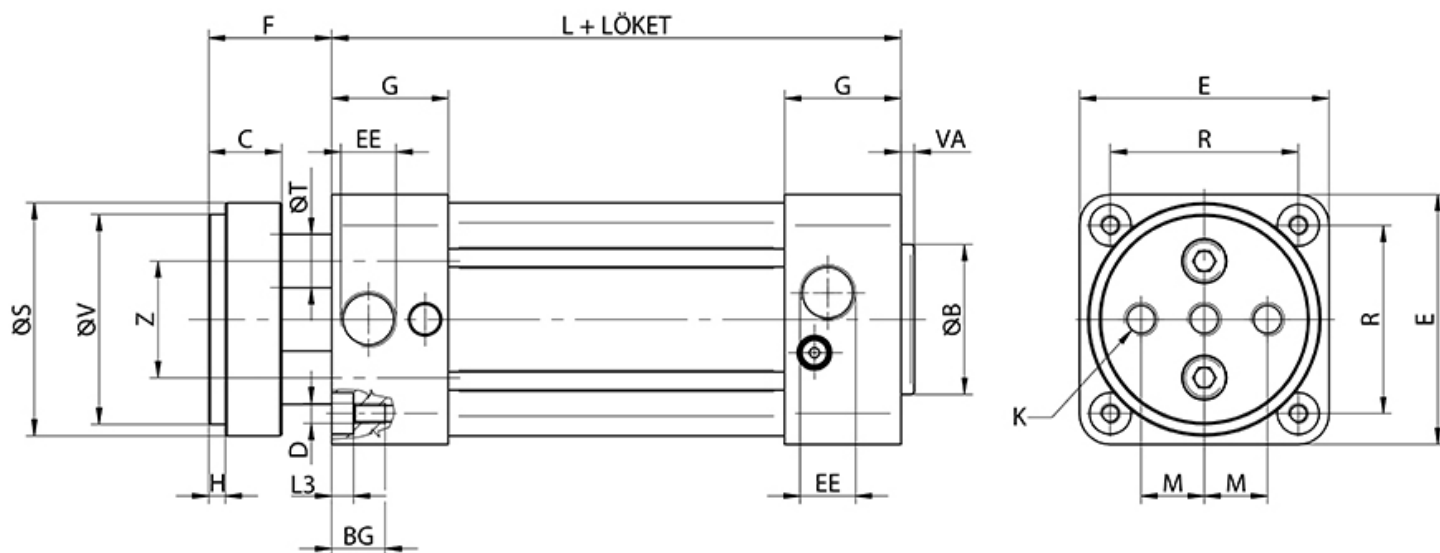

Típuszám	$\varnothing$ [mm]	B	C	E	F	H	K	M	S	T	V	Z	VA	L8	BG	RT	TG	EE	L3
DILD 32/...	$\varnothing 32$	$\varnothing 30$	26	47	4	15	M 6	9,5	$\varnothing 35$	$\varnothing 8$	$\varnothing 32$	18	4	94	16	M 6	32,5	G 1/8"	5
DILD 40/...	$\varnothing 40$	$\varnothing 35$	30	53	4	15	M 8	11,25	$\varnothing 45$	$\varnothing 10$	$\varnothing 40$	22	4	105	16	M 6	38	G 1/4"	5
DILD 50/...	$\varnothing 50$	$\varnothing 40$	37	65	5	18	M 8	15	$\varnothing 55$	$\varnothing 12$	$\varnothing 50$	26	4	106	16	M 8	46,5	G 1/4"	5
DILD 63/...	$\varnothing 63$	$\varnothing 45$	37	75	5	22	M 10	19	$\varnothing 70$	$\varnothing 16$	$\varnothing 63$	35	4	121	16	M 8	56,5	G 3/8"	5
DILD 80/...	$\varnothing 80$	$\varnothing 45$	46	95	5	22	M 12	25	$\varnothing 85$	$\varnothing 20$	$\varnothing 80$	40	4	128	17	M 10	72	G 3/8"	6,5
DILD 100/...	$\varnothing 100$	$\varnothing 55$	51	115	5	22	M 12	35	$\varnothing 105$	$\varnothing 20$	$\varnothing 100$	50	4	138	17	M 10	89	G 1/2"	6,5